

# RAVEN®

## PRIMARY BELT CLEANERS

**RAVEN PRE-CLEANER is an affordable yet efficient belt cleaner for light and medium duty applications**

RAVEN Pre-Cleaner is designed for long term performance at an affordable price.

The cleaner incorporates segmented Urethane Blade as the cleaning tip. The blade is mounted on a steel pipe main frame.

Standard cleaners are available off-the-shelf, complete with tensioners and mounting brackets. Colour coded Polyurethane blades suitable for different application and conditions are available on request.

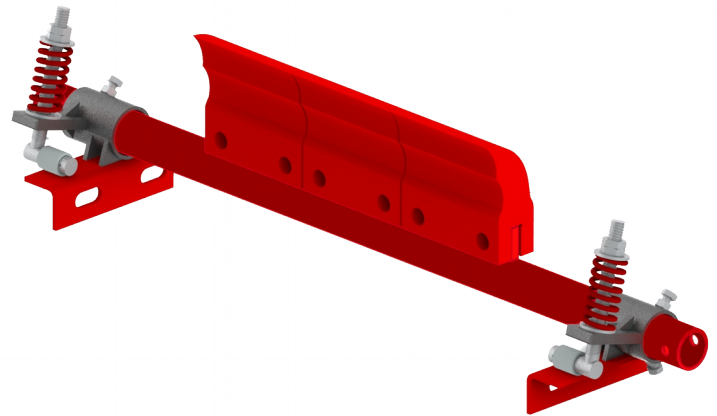

### SALIENT FEATURES

- Spring tensioners ensures optimum pressure exerted on the belt with maximum cleaning efficiency.
- The scraper's minimalistic design allows ease of installation and replacement of the blade even in confined spaces.
- Cleaners available for belt width 300mm to 1800mm.
- Segmented blade design allows economical operation of the cleaner. Each blade segment is 150mm wide.

### SPECIFICATIONS

<b>Blade Colour</b>	Red/Brown	Green
<b>Blade Width in.(mm)</b>	6 (150)	6 (150)
<b>Max. Service Temp.F (°C)</b>	158 (70)	257 (125)
<b>Max. Belt Speed fpm (M/s)</b>	700 (3.5)	700 (3.5)
<b>Wear Life in. (mm)</b>	2.75 (70)	2.75 (70)

## DIMENSIONS

Belt Width (mm)	Assembly P/N*	Dim A (mm)	Dim B (mm)	No. of Blades	Nett Weight (Kg)
300	TRP-0300-X-X	900	300	2	15.5
400	TRP-0400-X-X	1000	300	2	16.3
500	TRP-0500-X-X	1100	450	3	18.0
650	TRP-0650-X-X	1250	600	4	19.8
800	TRP-0800-X-X	1600	750	5	22.5
1000	TRP-1000-X-X	1800	900	6	24.5
1200	TRP-1200-X-X	1950	1050	7	29.8
1400	TRP-1400-X-X	2150	1200	8	32.1
1600	TRP-1600-X-X	2450	1500	10	36.3
1800	TRP-1800-X-X	2600	1650	11	38.4

\* Replace 1<sup>st</sup> X with R for RED, B for BROWN and G for GREEN blade.  
Replace 2<sup>nd</sup> X with S or W for Spring or Wire tensioner respectively.

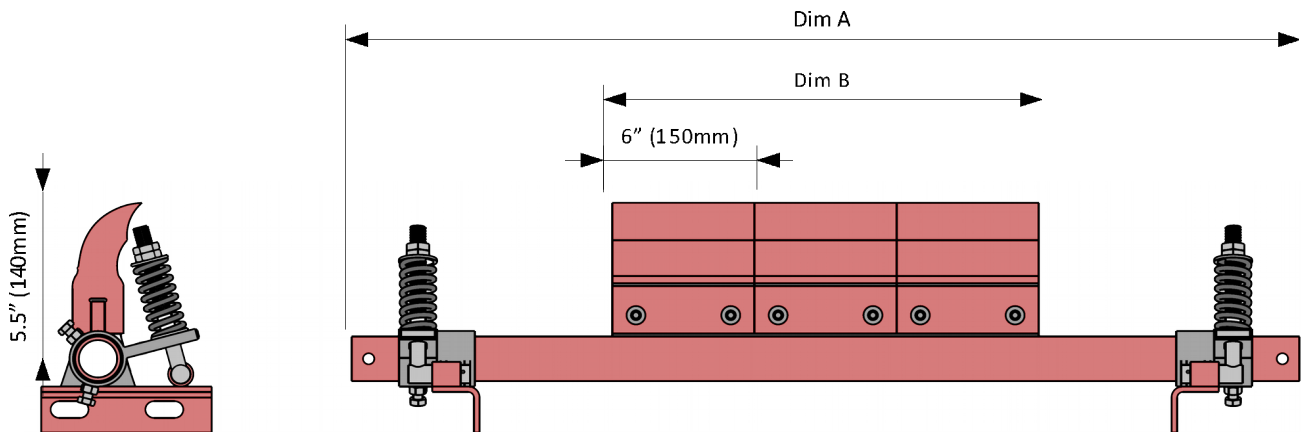

## ACCESSORIES & SPARES

Thejo provides a range of accessories for easy installation and maintenance of belt cleaners. They include mounting brackets, inspection doors, various tensioning devices etc. Custom made brackets and fittings are also available for specific applications.

<b>Spare Blade</b>	TCP-LD-SP-X
<b>Mounting Bracket</b>	TCP-LD-MB-XX
<b>Inspection Door</b>	TEL-BC-ID-XX-XX
<b>Tensioner</b>	TCP-LD-TR-S (Spring) TCP-LD-TR-W (Wire)

\* For more information please contact your nearest Thejo representative.