

FLEXISEAL

SKIRT BOARD SEALING SYSTEMS

FLEXI SEAL is a modular segmented skirt board sealing system suitable for Medium and Heavy Duty applications.

It consists of a serrated steel backing plate, modular rubber blocks and fasteners. The rubber blocks are 150mm wide and 20mm thick. Heavy Duty and Standard duty designs are available to choose from, depending upon the application.

Flexiseal-RS Rear Skirt sealing provide a complete sealing at the back skirt and prevents spillage of material due to material roll back. Rear Skirts are available in standard sizes. Customized back plates shall be provided on demand

Thejo's skirt sealing are designed in line with our policy of easy installation and maintenance. The various skirt sealing offered by Thejo have been introduced in the market after excessive field trials and numerous design improvisations to ensure fool proof performance.



Flexiseal-HD

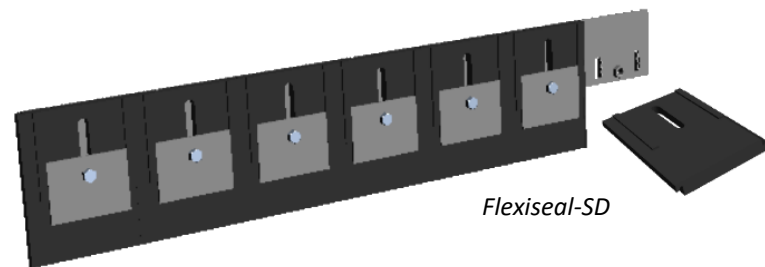

Flexiseal-SD

SALIENT FEATURES

- Provides outstanding control of fugitive material at loading zone with a Segmented and stepped approach to skirt sealing.
- Specially formulated rubber compound provides excellent wear properties for extended wear life.
- Available in various compounds to suit application such as HR grade (up to 180°C), FR Grade and Oil and Chemical resistant.
- Easily adjusts to the belt profile to provide effective sealing. Adjustment height ranges from 70mm to 100mm, depending upon skirt block height.
- Flexiseal rubber blocks are available in standard height of 200 mm.

SPECIFICATIONS

Maximum Service Temp.(Deg. C)	180°C
Maximum Height (mm)	200
Wear Length (mm)	70
Hardness (Shore A)	60 (+/-5)
Effective Width of Rubber Block (mm)	150
Thickness of Rubber Block (mm)	Standard Duty- 20 Heavy Duty -22

TECHNICAL DATA

Type of Skirt	Back Plate Thickness (mm)	Assembly Part No*
Flexiseal Standard Duty	3	TFS-SD-03-X-XX
Flexiseal Standard Duty	5	TFS-SD-05-X-XX
Flexiseal Heavy Duty	3	TFS-HD-03-X-XX
Flexiseal Heavy Duty	5	TFS-HD-05-X-XX
Flexiseal Rear Skirt**	3	TFS-RS-03-XXXX-X-XX
Flexiseal Rear Skirt**	5	TFS-RS-05-XXXX-X-XX

* Replace X with N if operating temperature is <70° C, H if operating temperature is 70° C-120° C & S if operating temperature is >120° C
 Replace XX with SS for Stainless Steel Backing Plate, leave blank for Mild Steel.

** Replace XXXX with Belt Width

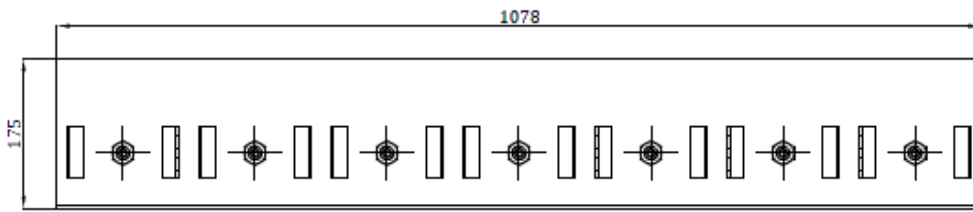

Flexiseal HD

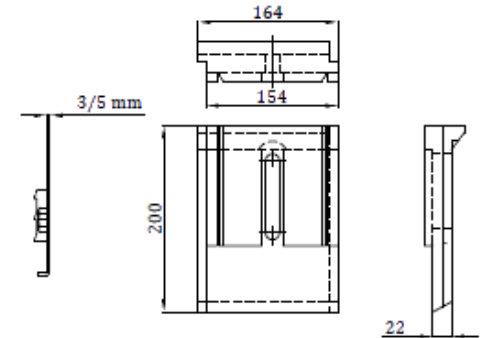

Flexiseal SD

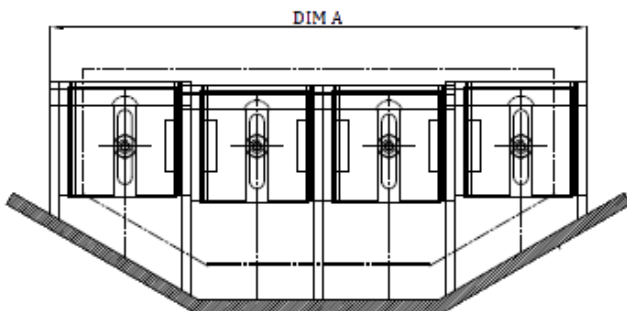
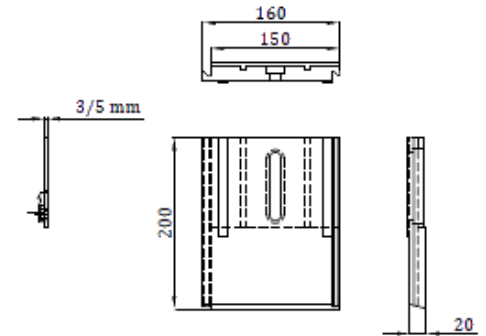

Flexiseal Rear Skirt

SPARES

Type of Skirt	Flexiseal SD	Flexiseal HD	Flexiseal RS
Rubber Block	TFS-SD-SR-X	TFS-HD-SR-X	TFS-RS-SR-X
Back Plate	TFS-SD-SB-XX	TFS-HD-SB-XX	TFS-RS-SB-XX-XXXX
Clamp Plate	TFS-SD-SC		